

**LOW VOLTAGE (1.25V) ADJUSTABLE PRECISION SHUNT REGULATOR****AZ432****General Description**

The AZ432 series ICs are low voltage three-terminal adjustable regulators with guaranteed thermal stability over a full operation range. These ICs feature sharp turn-on characteristics, low temperature coefficient and low output impedance, which make them ideal substitutes for Zener diodes in applications such as switching power supply, charger, motherboard and other adjustable regulators.

The output voltage can be set to any value between 1.25V and 18V with two external resistors.

The AZ432 precision reference is offered in two band-gap tolerance: 0.5% and 1%.

These ICs are available in 4 packages: TO-92, SOT-23-3, SOT-23-5, SOT-89.

**Features**

- Wide Programmable Precise Output Voltage from 1.25V to 18V
- High Stability under Capacitive Load
- Low Temperature Deviation: 3mV Typical
- Low Equivalent Full-Range Temperature Coefficient: 20PPM/°C Typical
- Low Dynamic Output Resistance: 0.05Ω Typical
- High Sink Current Capacity from 55μA to 100 mA
- Low Output Noise
- Wide Operating Range of -40 to 125°C

**Applications**

- Graphic Card
- PC Motherboard
- Voltage Adapter
- Switching Power Supply
- Charger

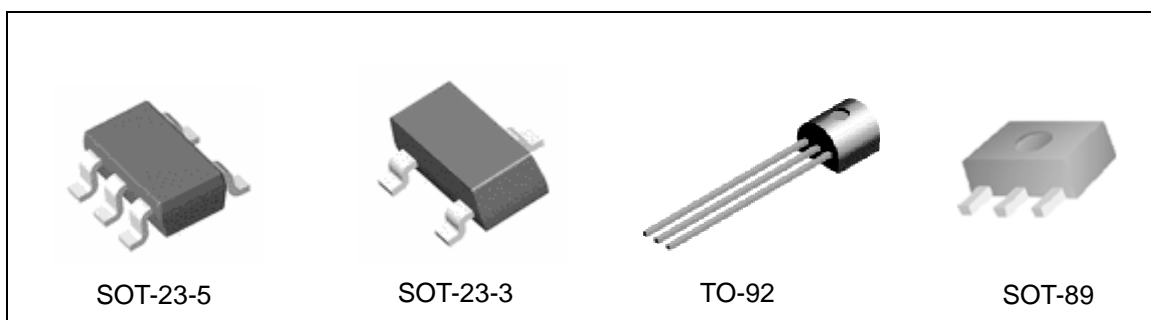

Figure 1. Package Types of AZ432